

Flip-Chip Assembled 7 GHz Ultra-Low Phase-Noise InGaP HBT Oscillator

Li-Han Hsu^{1,2}, Dan Kuylenstierna², Herbert Zirath², Edward Yi Chang¹, and Chin-Te Wang¹

1. Department of Materials

Science and Engineering, National Chiao-Tung University, Hsinchu 300,
Taiwan. (e-mail: edc@mail.nctu.edu.tw).

Phone number: +886-3-5712121-52971

2. Microwave Electronics

Laboratory, Department of Microtechnology and Nanoscience, MC2, Chalmers
University of Technology, Göteborg SE-412 96, Sweden.

(e-mail: lihan@chalmers.se)

Phone number: +46-3-177-236-603

Keywords: Flip-chip, Interconnection, MMIC, Oscillator, Phase noise, Microwave.

Abstract

This paper reports on a flip-chip assembled 7 GHz ultra-low phase-noise GaAs InGaP heterojunction bipolar transistor (HBT) monolithic microwave integrated circuit (MMIC) oscillator. The cross-coupled oscillator was flip-chip bonded to an in-house fabricated Al₂O₃ carrier with patterns optimized for low-loss transitions. After flip-chip, the phase noise of the cross-coupled InGaP HBT oscillator was improved due to an increased Q-factor of the resonant tank. An ultra-low phase-noise of -112 dBc/Hz @ 100 kHz offset and -128 dBc/Hz @ 1 MHz offset with a high output power of 7 dBm at 7 GHz was achieved. To our best knowledge, this is the lowest phase noise reported for a flip-chip assembled oscillator.

INTRODUCTION

Low phase-noise millimeter-wave (MMW) frequency generation is a critical issue for future multi-GB/s wireless communication systems. The MMW frequency bands are capable of carrying high data rates thanks to the large amount of bandwidth available, e.g., the license-free ISM (Industrial, Scientific and Medical) bands around 60 GHz [1], or the recently allocated E-band (71-76 GHz and 81-86 GHz) [2]. The 60 GHz band is considered to be used in several applications, e.g., multimedia communication, inter-vehicle communication, and roadside communication. To enable such systems, signal generation with stabilized frequency and low phase noise is needed [3]. However, frequency generation with low phase noise is challenging at MMW frequencies. One solution could be to operate the local oscillator at a lower frequency and use frequency multipliers [3] to reach the target frequency. It is believed that the overall phase noise will be lower with this approach as the Q-factor of the resonant tank in the oscillator is reduced with increased

frequency [4]. The use of frequency multipliers to create millimeter-wave signals also decrease or even totally diminish the need of frequency dividers for phase-locking.

Although it is possible to design single-chip solutions where the oscillator and multiplier are integrated on the same MMIC, it may be advantageous to address a multi-chip module (MCM) [5] approach enabling higher flexibility in choice of technology for each chip. However MCM packaging at millimeter-wave frequencies is also challenging, the interconnections between the MMIC chips and the MCM carrier may decay the assembly performance, e.g., conventional bond-wires give a significant contribution to the parasitic inductance and thus induce unwanted effects at millimeter-wave frequencies [6]. In this respect, flip-chip interconnection has been regarded as a promising packaging technology for cost-effective module assembly in millimeter-wave systems due to its shorter interconnect length, higher throughput, and smaller package size [7]-[9]. For these reasons, flip-chip based multi-chip module (FC-MCM) is considered as the most promising packaging scheme for millimeter-wave wireless applications.

This study investigates the flip-chip effect on low frequency (7 GHz) local oscillator, intended to demonstrate the feasibility of using this approach (combining with frequency multipliers) for low phase-noise mm-wave frequency generation.

7 GHz CROSS-COUPLED HBT OSCILLATOR

The oscillators were designed and simulated in Advanced Design Systems (ADS) using the harmonic balance tool. The EM (Electromagnetic) simulation tool Momentum is used for optimization of passive elements. The aim of the investigation is to reach lowest possible phase noise by optimizing the varactor geometry. Previous investigations have shown that balanced colpitts and cross-coupled topologies are good candidates for low phase noise [10]. Fig.

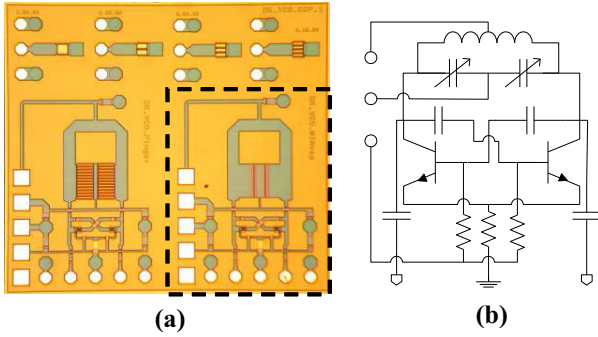

Fig. 1. (a) Chip photograph (the right one) and (b) circuit schematic of the

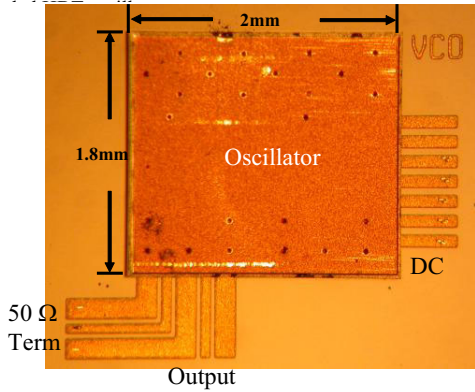

Fig. 2. Photograph of the flip-chip bonded HBT oscillator.

1 shows the chip photograph and circuit schematic of the cross-coupled HBT oscillator used in this study. There are two circuits in the same chip. The circuit on the right side is the fixed-frequency oscillator used in this study. Since the two circuits were not separated by dicing, the circuit on the left side was used as additional support by designing dummy bumps underneath its pads. The total chip area is $1.8 \times 2 \text{ mm}^2$.

FLIP-CHIP ASSEMBLY

The oscillator was assembled using standard in-house flip-chip process in the Compound Semiconductor Laboratory (CSDLab) [11]. Fig. 2 shows the photograph of the flip-chip bonded HBT oscillator. To investigate the influence of the flip-chip mounting, an EM simulation was carried out in ADS-Momentum. Fig. 3 shows a cross-sectional view of the

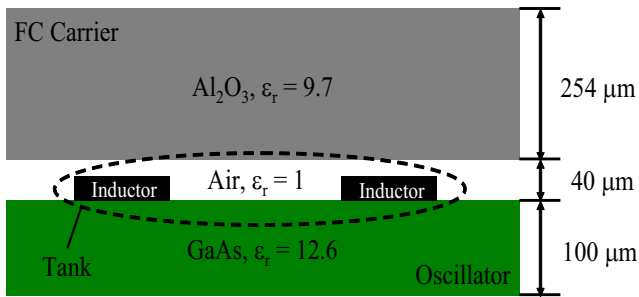

Fig. 3. Cross-sectional view of the simulated resonant tank of the oscillator taking the flip-chip effect into account.

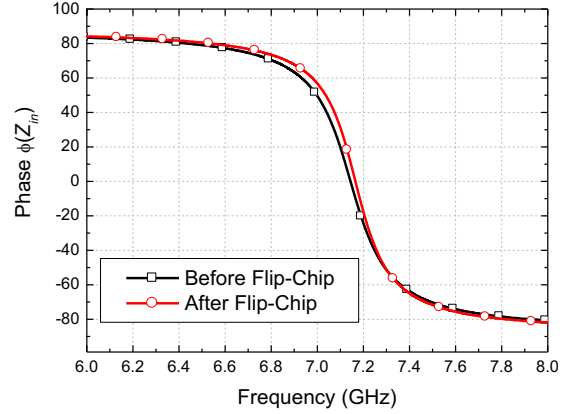

Fig. 4. Simulated phase of the input impedance $\phi(Z_{in})$ of the oscillator versus frequency before and after flip-chip assembly.

simulated resonant tank of the oscillator with the effect from the flip-chip carrier taken into account. A $40 \mu\text{m}$ thick layer of air layer and a $254 \mu\text{m}$ thick Al_2O_3 layer were added to represent the flip-chip carrier in the Momentum substrate definition. Fig. 4 shows the simulated phase of the input impedance $\phi(Z_{in})$ versus frequency before and after flip-chip assembly. From the phase-frequency curve in Fig. 4, the Q-factor can be calculated as:

$$Q = \frac{-\omega_0}{2} \left| \frac{\partial \phi(Z_{in})}{\partial \omega} \right|_{\omega=\omega_0} \quad (1)$$

The calculated Q-factors before and after the flip-chip are estimated to be 28 and 33, respectively, i.e., 18 % improvement in Q-factor of the resonant tank after flip-chip assembly. In both cases the resonant-frequency was 7.2 GHz, the shift in resonant frequency due to Al_2O_3 is negligible. To predict the oscillator phase-noise, the S-parameters from the Momentum simulation were inserted into the oscillator equivalent-circuit and the phase noise simulated with the Harmonic Balance tool in Agilent Advanced Design System. The simulated and measured phase noise are shown in Fig. 7. Due to the higher Q-factor, the phase noise is improved after flip-chip as expected.

MEASUREMENT RESULTS

As seen in Fig. 1, the cross-coupled oscillator has a balanced output. The characterization of the circuit was accomplished by measuring one of the outputs, while the other was terminated in a 50Ω load. Both outputs were also externally attenuated 3 dB to reduce the loading of the oscillator. Fig. 5 shows the measured dc current consumption of the oscillator, i.e., I_c versus V_{bb} at $V_{cc} = 8 \text{ V}$, before and after flip-chip assembly. After flip-chip, the current consumption was lower. Although the reduction was marginally within the range of the measurement accuracy, a slight reduction could be expected due to the improved tank-

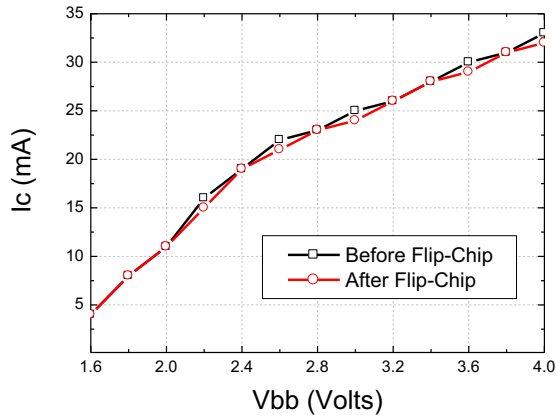

Fig. 5. Measured collector current of the oscillator before and after flip-chip assembly. The collector bias voltage is $V_{cc}=8V$.

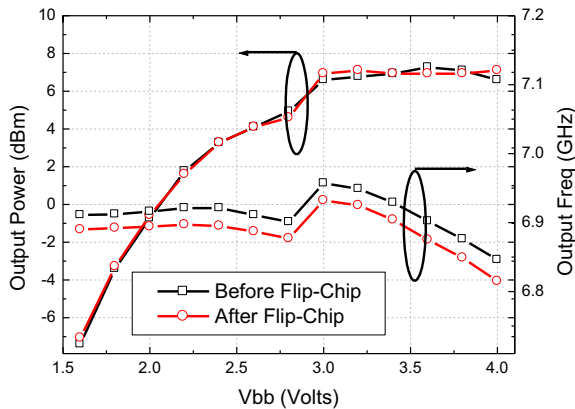

Fig. 6. Measured output power and frequency of the oscillator as function of the base voltage (V_{bb}) before and after flip-chip.

Q. Fig. 6 shows the measured output power and oscillation frequency versus base voltage (V_{bb}). After flip-chip assembly the output power remained the same and the oscillation frequency was shifted as little as 25 MHz (0.35%). Fig. 7 shows measured and simulated phase noise for the flip-chipped oscillator and the probed MMIC oscillator compared to simulations. As can be seen in Fig. 7, the phase noise was improved after flip-chip assembly, probably due to the better Q-factor resulting from the mounting effect of the flip-chip. The simulation and measurement results correspond well below $V_{bb} = 3 V$. Above $V_{bb} = 3 V$, the simulated results does not agree with the measurements, the reduced phase noise in simulation is most likely an artifact from model limitations when the oscillator goes into the voltage limited region. After flip-chip assembly, the lowest phase noise are -112 dBc/Hz @ 100 kHz offset and -128 dBc/Hz @ 1 MHz offset. Compared to the previous publications [12]-[19], this is the lowest phase noise reported for a flip-chip assembled oscillator. Table I presents the key-figures of the flip-chip oscillator in this work compared to flip-chip oscillators in open literature. To be able to compare phase noise of oscillators operating at

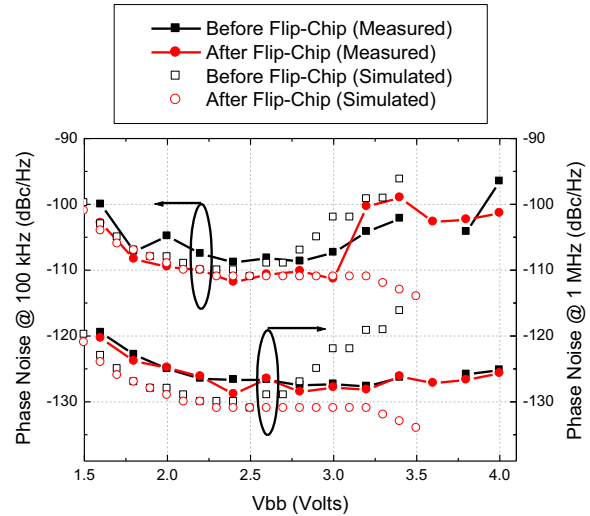

Fig. 7. Measured and simulated phase noise of the oscillator before and after flip-chip assembly. The collector bias voltage is $V_{cc}=8V$.

different frequencies, the results are bench-marked after a normalized phase noise (PN_{norm}) at 1 GHz and 100 kHz off-set, calculated using Leeson's equation [20].

$$PN_{\text{norm}} = PN_{\text{dB}} - 20 \log \left\{ \frac{100 f_0}{\Delta f} \right\} = PN_{\text{dB}} - 40 - 20 \log \left\{ \frac{f_0}{\Delta f} \right\}$$

(2)

Where f_0 is the oscillation frequency in GHz and PN_{dB} is phase noise measured at an off-set frequency Δf [kHz]. The figure of merit PN_{norm} resembles the conventional oscillator FOM [21] apart from the fact that it does not include the power consumption which is intentionally omitted as it mixes up two parameters into the same figure of merit. The dc power consumption of the oscillator in this work is $P_{dc} = 8 \times 20 = 160 \text{ (mW)}$, which would yield a FOM of -187 using the definition in [21], which is very competitive. However, it is better to present phase noise and power consumption individually. First the requirements on phase noise must be

Table I The flip-chip oscillator in this work compared to flip-chip oscillators in open literature

Flip-Chip oscillator	Device Technology	Frequency (GHz)	Phase Noise (dBc/Hz)	Normalized Phase Noise (1 GHz, 100 kHz)
[12]	CMOS	2.4	-108 @ 600 kHz	-100
[13]	CMOS	4	-126 @ 1MHz	-118
This Work	HBT	6.9	-111.33 @ 100 kHz -128.83 @ 1 MHz	-127.8
[14]	pHEMT	27	-84 @ 1 MHz	-92.6
[15]	pHEMT	27.55	-109 @ 1 MHz	-117.8
[16]	AlGaAs/InGaAs FET	31.7	-90 @ 1 MHz	-100
[17]	Gunn	34.45	-83.7 @ 100 kHz	-114.4
[18]	Gunn	58.74	-87.67 @ 100 kHz	-123
[19]	Gunn	76	-104 @ 1 MHz	-121.6

fulfilled. Then it must be verified that the power consumption is not too high for the application in mind.

It should be mentioned that data compared in this work are measured with the HP8565EC spectrum analyzer, the MMIC oscillator was also measured using a dedicated phase noise measurement system Agilent 5500A with better noise floor. Then a phase noise as low as -117 dBc/Hz at 100 kHz off-set was reached [10].

CONCLUSION

This work successfully demonstrates flip-chip assembly of a 7 GHz low phase-noise cross-coupled HBT oscillator with an ultra-low phase noise for mm-wave frequency generation. It is shown that flip-chip bonding is an excellent assembly technology for the implementation of millimeter-wave frequency sources. Compared with the bare-die measurements, the flip-chip technology does not have any detrimental effect on the chip performance. On the contrary, the chip performance was improved. After flip-chip, the phase noise of the cross-coupled InGaP HBT oscillator was improved due to an increased Q-factor of the resonant tank.

ACKNOWLEDGEMENT

This research has been carried out in GigaHertz Centre in a joint project financed by Swedish Governmental Agency of Innovation Systems (VINNOVA), Chalmers University of Technology, Ericsson AB, and Sivers IMA AB. The authors would like to thank to Szu-Ping Tsai and Wee-Chin Lim in the Compound Semiconductor Laboratory, National Chiao-Tung University for the help of the Al₂O₃ carrier fabrication.

REFERENCES

- [1] P. Smulders, "Exploiting the 60 GHz band for local wireless multi-media access: Prospects and future directions," *IEEE Commun. Mag.*, pp. 140-147, Jan. 2002.
- [2] Val Dyadyuk, John D. Bunton, Joseph Pathikulangara, Rodney Kendall, Oya Sevimli, Leigh Stokes, and David A. Abbott, "A Multigigabit Millimeter-Wave Communication System With Improved Spectral Efficiency," *IEEE Trans. Microwave Theory Tech.*, vol. 55, issue 12, Dec. 2007.
- [3] C. Kärnfelt, R. Kozuharov, H. Zirath, and I. Angelov, "High-purity 60-GHz-band single-chip x8 multipliers in pHEMT and mHEMT technology," *IEEE Trans. Microwave Theory and Tech.*, vol. 54, issue 6, pp. 2887-2898, June 2006.
- [4] H. Zirath, R. Kozuharov, and M. Ferndahl, "Balanced Colpitt oscillator MMICs designed for ultra-low phase noise," *IEEE Journal of Solid-State Circuits*, vol. 40, issue 10, pp. 2077-2086, Oct. 2005.
- [5] K.K. Samanta, D. Stephens, and I.D. Robertson, "60 GHz multi-chip-module receiver with substrate integrated waveguide antenna and filter," *Electronics Letters*, vol. 42, pp. 701-702, June 2006.
- [6] G. Baumann, H. Richter, A. Baumgärtner, D. Ferling, and R. Heilig, "51 GHz front-end with flip-chip and wire bond interconnections from GaAs MMIC's to a planar patch antenna," *IEEE MTT-S International Microwave Symposium Digest*, Orlando, FL/USA, 16-20 May 1995, vol. 3, pp. 1639-1642.
- [7] C.L. Wang, and R.B. Wu, "Modeling and design for electrical performance of wideband flip-chip transition," *IEEE Trans. Advanced Packaging*, vol. 26, issue 4, pp. 385 - 391, Nov. 2003.
- [8] K. Maruhashi, M. Ito, H. Kusamitsu, Y. Morishita, and K. Ohata, "RF performance of a 77 GHz monolithic CPW amplifier with flip-chip interconnections," *IEEE MTT-S International Microwave Symposium Digest*, Baltimore, MD/USA, June 7-12, 1998 vol. 2, pp. 1095-1098.

- [9] A. Jentzsch and W. Heinrich, "Theory and measurements of flip-chip interconnects for frequencies up to 100 GHz," *IEEE Trans. Microwave Theory and Tech.*, vol. 49, issue 5, pp. 871-878, May 2001.
- [10] Dan Kuylenstierna, Herbert Zirath, Rumen Kozuharov, Mingquan Bao, and TC Tsai, "Low phase noise MMIC oscillators in InGaP HBT technology," *Asia Pacific Microwave Conference 2008*, Hong Kong, Dec. 2008.
- [11] W.C. Wu, H.T. Hsu, E. Y. Chang, C.S. Lee, C.H. Huang, Y.C. Hu, L.H. Hsu, and Y.C. Lien, "Flip-chip packaged In_{0.52}Al_{0.48}As/InGaAs metamorphic HEMT device for millimeter wave application," in *Proc. CS-MAX, Compound Semicond. Manufact. Expo*, Palm Spring, CA/USA, Nov. 2005, pp. 94-97.
- [12] X. Huo, G-W Xiao, P.C.H. Chan, and K.J. Chen, "Silicon-on-Organic Integration of a 2.4-GHz oscillator Using High-Q Copper Inductors and Solder-Bumped Flip Chip Technology," *IEEE Transactions on Components and Packaging Technologies*, Vol. 32, issue 1, pp. 191-196, March, 2009.
- [13] K. Stadius, and K. Halonen, "Development of 4-GHz flip-chip oscillator module," *IEEE International Symposium on Circuits and Systems, 2005. ISCAS 2005*, Kobe, Japan, 23-26 May 2005, vol. 3, pp. 2687-2690.
- [14] Y.M. Hsin, Y.A. Liu, C.M. Wang, W.K. Huang and T.J. Yeh, "27 GHz Flip-Chip Assembled pHEMT Oscillator," in *Proc. CS-MAX, Compound Semicond. Manufact. Expo*, Vancouver, British Columbia/Canada, 24-27 April 2006, pp. 127-129.
- [15] W.K. Huang, Y.A. Liu, C.M. Wang, Y.M. Hsin, C.Y. Liu, and T.J. Yeh, "Flip-Chip Assembled GaAs pHEMT Ka-Band Oscillator," *IEEE Microwave and Wireless Components Letters*, vol. 17, issue 1, pp. 67-69, Jan. 2007.
- [16] M. Ito, K. Maruhashi, S. Kishimoto, T. Hashiguchi, and K. Ohata, "A 30 GHz-band oscillator coupled with a dielectric resonator using flip-chip bonding technique," *2004 IEEE MTT-S International Microwave Symposium Digest*, Fort Worth, TX/USA, 6-11 June 2004, vol. 3, pp. 1995-1998.
- [17] T. Yoshida, T. Deguchi, K. Kawaguchi, and A. Nakagawa, "Ka-band planar Gunn oscillators using flip-chip GaAs Gunn diodes fabricated by boron ion implantation," *22nd Annual Gallium Arsenide Integrated Circuit (GaAs IC) Symposium, 2000*, Seattle, WA/USA, 5-8 Nov. 2000, pp. 165-168.
- [18] K. Watanabe, T. Deguchi, and A. Nakagawa, "V-band planar Gunn oscillators and VCOs on AlN substrates using flip-chip bonding technology," *1999 IEEE MTT-S International Microwave Symposium Digest*, Anaheim, CA/USA, 13-19 June 1999, vol. 1, pp. 13-16.
- [19] T. Yoshida, Y. Fukasawa, T. Deguchi, K. Kawaguchi, T. Sugiyama, and A. Nakagawa, "A low-phase-noise 76-GHz planar Gunn oscillator using flip-chip bonding technology," *2005 European Microwave Conference*, Paris, France, 4-6 Oct. 2005, vol. 1.
- [20] D. B. Leeson, "A simple model of feedback oscillator noise spectrum," in *Proc. IEEE*, Feb. 1966, vol. 54, pp. 329-330.
- [21] M.Q. Bao, Y.G. Li, and H. Jacobsson, "A 21.5/43-GHz dual-frequency balanced Colpitts VCO in SiGe technology," *IEEE Journal of Solid-State Circuits*, vol. 39, issue 8, pp. 1352-1355, Aug. 2004.